

ZETHS



Boger Owner's Manual

Rebuilding is strictly prohibited

Important notices

These warning symbols occur in several places. Whenever you see the symbols shown below, heed their instructions! Always follow safe operating and maintenance practices.



Indicates a hazardous situation which if not avoided will result in serious injury or death.



Indicates that a hazardous situation, which if not avoided, could result in serious injury or death.



Notice is used to address practices not related to personal injury.

Attention:

Pay special attention to this section

Content

Before driving	1
Common information	3
Serial number	4
Frame number	4
Engine number	4
Vehicle data plate	4
Parameter	5
Motorcycle view	7
Back left view	7
Front right view	8
Operating components	9
Clutch handle	9
Brake handle	9
Left handle switch	10
Right handle switch	10
Throttle handle	10
Lock set	11
Shift bar	12
Brake pedal rod	12
Side brace	12

Instrumentation	13
Fuel system	16
Fuel tank	16
Fuel requirements	16
Octane value grade	16
Engine assembly	17
Engine oil level inspection	17
Renewal engine oil and filter	18
Engine oil volume	19
Idling	20
Air inlet/outlet system.....	21
Oil gas discharge monitor system	21
Intake valve	21
Air door clearance	21
Air filter	22
Throttle valve body	22
Tire and chain	23
Tyre specification	23
Tyre load	23
Tyre wear	23

Drive chain inspection	24
The degree of elasticity of drive chain adjustment	25
Braking system	26
Front braking handle inspection	26
Back braking pedal bar inspection	26
Brake oil level inspection	27
Brake liquid supplement	28
Brake tray inspection	30
Brake pincers inspection.....	30
Damper	31
Spring front fork inspection	31
Back damper adjustment	31
Electric and light signal	32
Storage battery	32
Light	33
Fuse	34
Catalyse device	35
How to drive this vehicle	36
Start vehicle	36
Vehicle starting	37

Shift, driving	37
Braking	38
Parking	39
Safety driving	40
Safety driving technique	40
Daily safety inspection	41
Special notices when high speed driving	42
Run-in period	43
Maintain period	44
Daily maintain table	44
Maintain table in run-in period	45
Maintain table after run-in period	47
Common failure and reasons	52

Before driving

Warning

Do not remove any warning label. They allow you and others to view potential dangers.

Danger

This product requires a licensed driver.

Pay attention to the below information:

The user should check each component of the motorcycle according to the daily safety inspection chapters before driving, and to maintain safety.

The users should follow the local laws and regulations.

Do NOT drive the motorcycle after consuming alcohol or controlled substances.

Please wear the suitable protection equipment during whole driving process, such as helmet, boots, and gloves.



 **Danger**

Users are prohibited from rebuilding the unit. Improper rebuild will result in damages to person and unit.
Do not Rebuild the device or any electrical component of this product.
Incorrect load actions may cause serious results.
Incorrectly installed accessories may cause a potential safety hazard.

Always use the original Massimo components and the accessories which are approved by Massimo Motor Sports LLC. Using non original Massimo components, incorrectly installing accessories or load all will affect the overall performance. Please be responsible for yourself and other riders.

 **Warning**

This motorcycle was configured using components and accessories passed through special design verifications, so we strictly recommend that you use Massimo original components and install the accessories which are approved by us.

 **Warning**

Do not exceed the loaded cargo weight or number of carried passengers. Failure to adhere to this warning will result in a weight change that will affect the performance and can result in injury or death.

The max load: is 150kg (driver, luggage and accessories).

Common information

Please pay attention before driving

1. Read this owners manual carefully before riding so that you will be thoroughly familiar with the proper operation of your motorcycle's controls, its features, capabilities, and limitations. This manual offers many safe riding tips, but it's purpose is not to provide instruction in all of the techniques and skills required to ride a motorcycle safely.

Motorcycles are sensitive to changes in weight and aerodynamic forces, so you must take extreme care in carrying cargo, passengers and/or in fitting additional accessories.

2. Massimo strongly recommends that all operators of this vehicle complete a motorcycle riding program to learn the proper skills and techniques necessary for safe motorcycle operation.

3. It is important to keep your motorcycle properly maintained and in safe riding condition. Inspect your motorcycle before every ride and carry out all periodic maintenance. See the Section for MAINTENANCE.

4. If equipped with two seats, never carry more than one passenger.

5. The passenger should only sit on the seat.

6. Any passenger should be thoroughly familiar with motorcycle operation. The passenger can affect the control of the motorcycle during cornering and sudden movements. It is important that the passenger sit still while the motorcycle is in motion and not interfere with the operation of the motorcycle.

7. All baggage should be carried as low as possible to reduce the effect on the motorcycle's center of gravity. Do not carry heavy or bulky items on the luggage rack.

8. This motorcycle is NOT intended to be equipped with a sidecar or to tow trailers or other vehicles.

Serial number

The engine and frame serial numbers are used to register the motorcycle and are the only means to identify your particular machine. Please record your Serial Numbers below.

Frame number

Engine number

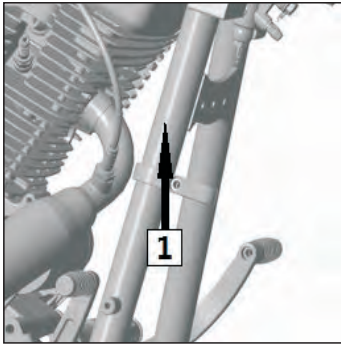

1 Frame number

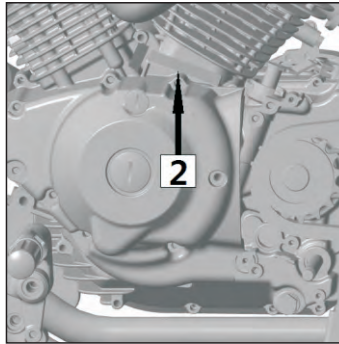

2 Engine number

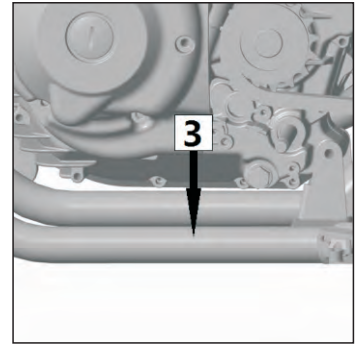

3 Motorcycle data plate

Parameter

Voger 250	
Performance	
The max net power	14Kw/8000rpm
The max torque	18N·m/6500rpm
The min turn diameter	5.6m
The highest design speed	74 mph
Size	
Full length	93.3 in
Full width	28.3 in
Full height	36.2 in
Shaft distance	70 in
Seat height	25.2 in
Clearance of leave ground	4. in
The whole set mass	386 lbs
Engine	
Type	Double cylinders, four stroke, V-type
Output volume	0.3 qts
Cylinder diameter×stroke	49X66mm
Compress ratio	10.0 : 1
Start system	Electric start
Fuel supply method	EFI
Ignition control method	ECU ignite

Lubricating system	Pressure splash lubricating	
Engine oil type	SAE 15W/40 Grade SJ JASOMA2 certified engine oil	
Coolant capacity	11.26 qts + 0.12 qts	
Transmission		
Shifting method	Five gears shifting International standard gear	
Clutch type	Wet type multiply sheets type manual clutch	
Drive system	Chain driven	
Primary moderate ratio	2.800	
Terminal moderate ratio	2.929	
Chassis		
Tyre specification	Front wheel	4.0-17
	Rear wheel	4.0-17
Wheel rim specification	Front wheel	17×MT3.0
	Rear wheel	17×MT3.0
Fuel tank volume	1.8 gal	
Oil consumption per hundred kilometre	0.87 gal	
Electric device		
Storage batteries	12V/7Ah	
Front light	Halogen	
Tail lamp/brake lamp	Halogen	

Motorcycle view

Back left view

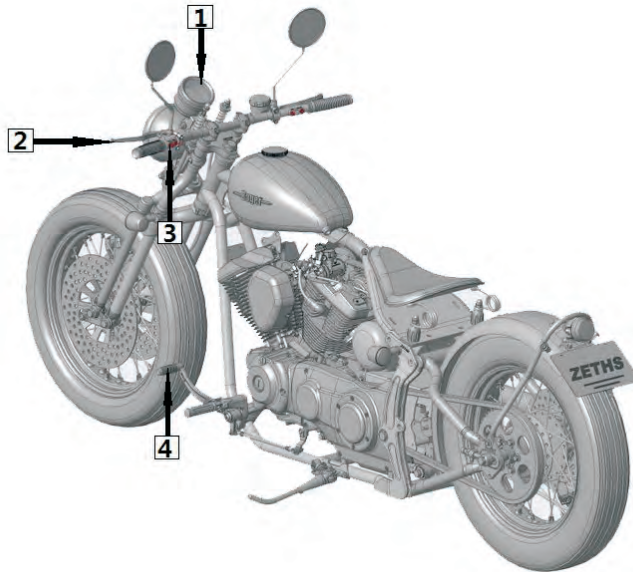

- 1 Meter
- 2 Clutch Lever
- 3 Kill Switch
- 4 Shift lever

Back right view

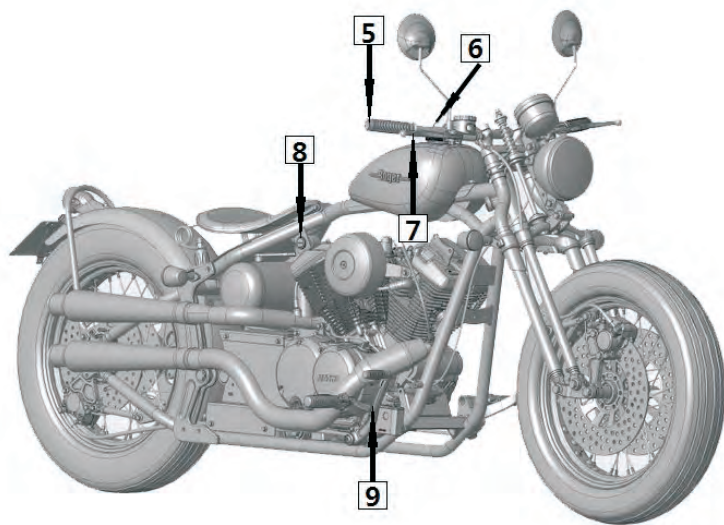

- 5 Throttle handle
- 6 Turn signal switch/lights
- 7 Brake lever
- 8 Ignition switch
- 9 Rear brake lever

Operating components

Clutch handle

Clutch handle: located on the left side, used prior to shifting



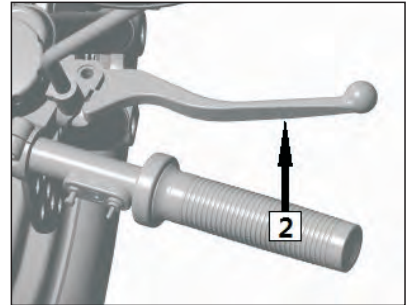

Front Brake handle

Brake handle: located on the right side, used to apply front brakes. Use with CAUTION. Excessive application can cause rider to lose control.



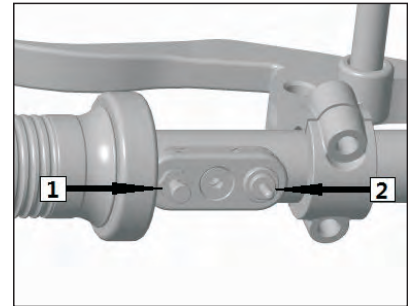

Left handle switch

1	Horn switch		Press this button to sound horn
2	Turn Signal Switches		Toggle Right for Right Turn Signal
			Toggle Left for Left Turn Signal



Right handle switch

1	Start switch		Press to engage the starter
2	Headlight Switch		Toggle Right for High Beam Headlight
			Toggle Left for Low Beam Headlight

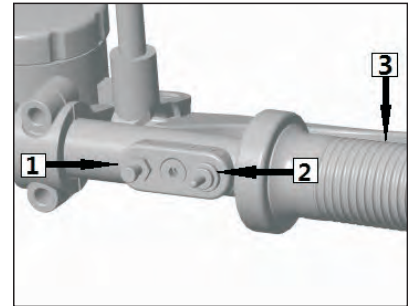



Pull Throttle

Pull throttle: pull back to accelerate. release to decelerate.

Lock set

Ignite switch lock **1**

Handle Bar lock		Located at the base of the triple tree on the right side of the steering neck. Turn handles completely to the left to lock.
Ignition Off		Illustration shows a continuous arrow with an X. This is your "OFF" position.
Start		Illustration shows a continuous arrow without an X. This is your "ON" position.

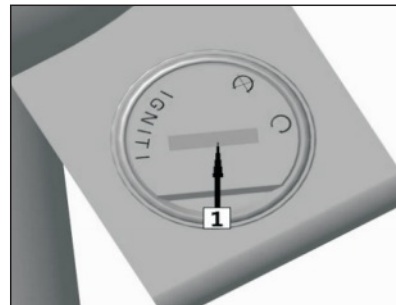

Fuel tank gas cap **2**

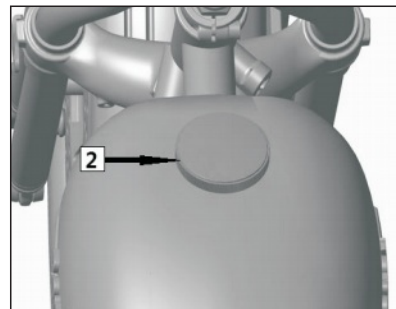

Shift bar

Shift bar **1** locate at left side of engine

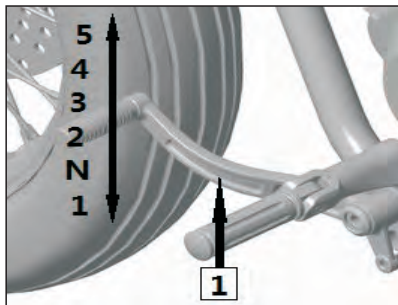

Brake pedal rod

Brake pedal **2** located at right side of engine, use the brake pedal bar to apply rear brakes.

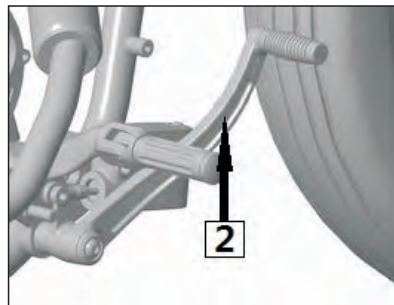

Side stand

Side brace **3** located at left side of motorcycle, used to park the motorcycle; motorcycle unable to start when side is down.

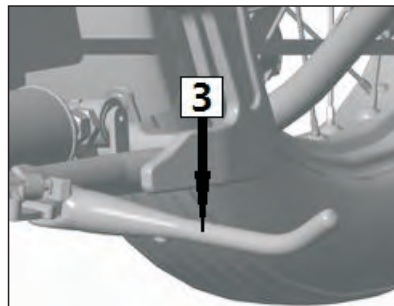

Instrument

Instrument indicate lamp
(black-white)

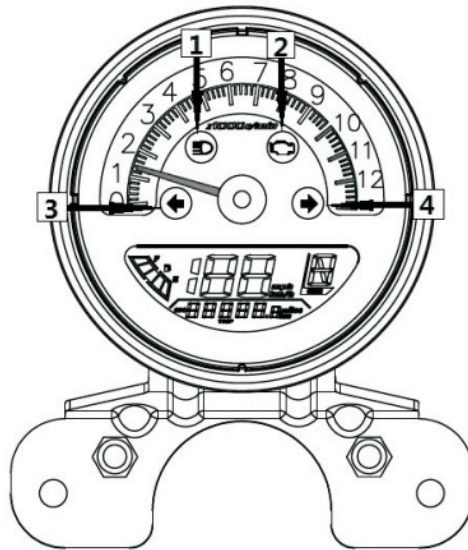

- 1 High beam indicator
- 2 MIL Light
- 3 Left turn signal
- 4 Right turn signal

High beam indicator -1

This indicator will light up when high beam is on.

Check/ Engine light: -2

This indicator will show when an engine/sensor error or malfunction has occurred.

Turn signal indicator: -3.4

Turn signal indicator 3 will flash when left turn signal is in the on position

Turn signal indicator 4 will flash when right turn signal is in the on position

Meter

Back of instrument
(black-white)

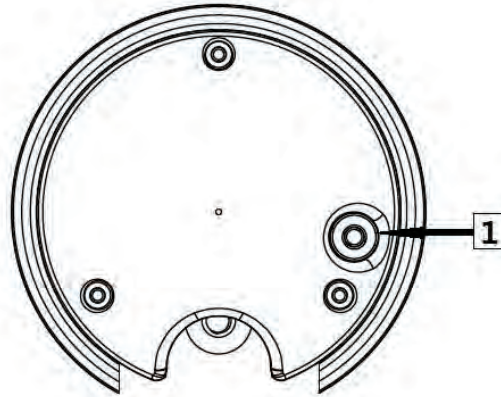

Rear Meter Settings Button:

1. Click to cycle through option: mileage kmh/mph and lighting settings
2. Long press the settings button under the total mileage status when total mileage lower than 50 kilometer/ 30 miles,this has one time reset on total mileage function.
3. Long press the settings button under trip mileage status this will reset the trip mileage.
4. Long press settings button for 6 seconds this will change the meter color orange or blue

Fuel system

WARNING:

Gasoline is extremely flammable and can be explosive under certain conditions, creating the potential for serious burns. Turn the ignition switch off. Do not smoke; make sure the area is well ventilated and free from any source of flame or sparks; this includes any appliance with a pilot light. Never fill the tank completely to the top. If the tank is filled completely to the top, heat may cause the fuel to expand and overflow through the vents in the tank cap. After refueling, make sure the tank cap is closed securely. If gasoline is spilled on the fuel tank, wipe it off immediately.

Fuel tank volume: 1.7 gallons

Fuel requirements Use minimum of 87 octane gasoline only to prevent severe engine damage.



If engine “knocking” or “pinging” occurs, use a different brand of gasoline of a higher octane rating. If this condition is Allowed to continue it can lead to severe engine damage. Gasoline quality is important.

Octane value grade

Never use gasoline with an octane rating lower than the minimum specified by Massimo. We recommend using a fuel stabilizer mixed in the fuel when not using your motorcycle for 30 to 60 days.



Please use best quality or more higher octane value non lead gasoline if engine occur knock cylinder or explode vibration.

Maintenance

- (1) If the engine is cold, start the engine and run it several minutes at idle speed.
- (2) Stop the engine, then wait several minutes until the oil settles.



Warning

Reving the engine before the oil reaches every part can cause engine seizure.

Engine oil level inspection

(3) check the engine oil level through the oil level inspection window. With the motorcycle held level, the oil lever should come up between the upper and lower level lines next to the oil level inspection window .

(4) If the oil level is too high, remove the excess oil through the oil filler opening using a syringe or some other suitable device.

(5) If the oil level is too low, add oil to reach the correct level. Only use oil specified in this manual.

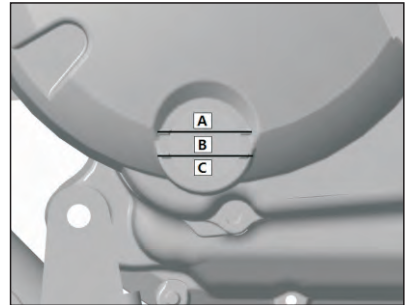

Changing oil and oil filter

Use side brace to support the motorcycle on level ground;
Idle the motor for several minutes until the machine is warm.

Warning

If you allow the engine to idle too long it will become very hot and can cause dangerous burns. Seek emergency help immediately if you become burned.

Place one oil basin under the oil discharge position;
Remove the bolt and washer **1**;

Completely discharge the waste engine oil in an approved manor;

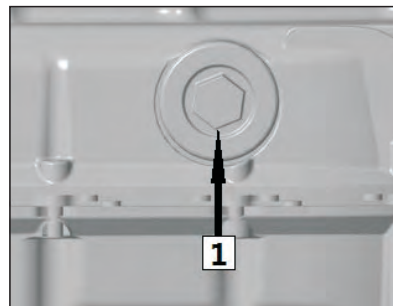

Warning

Dispose of used oil appropriately. Do not discard down the drain or in the trash.

Disassemble the engine oil filter cover **2** and renew the new engine oil filter element;

Reinstall engine oil filter;

Warning

Please coat one layer oil film on the filter seal ring when install the engine oil filter.

Clean the oil drain bolt and the oil discharge port;
Reinstall oil discharge bolt and washer;

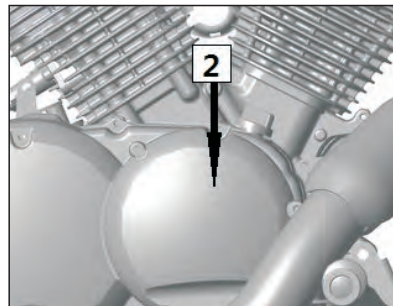

Tighten torque: 25N•m

Remove the oil fill port screw stopper [3];

Add 1.26 qts SAE ISW/40 Grade SJ JASOMA2 certified engine oil;

Reinstall the oil fill port screw stopper;

Tighten torque: 25N•m

Idle engine few minutes to fill engine oil into engine oil filter;

Turn off engine; check the engine oil level, and add/remove oil according to actual oil level.

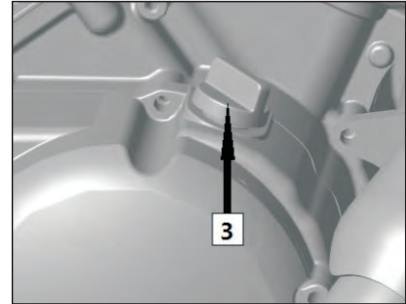

Engine oil volume

When renewal engine oil filter: 1.2L

We required to use the engine oil APISH level and above, first choice to use JASOMA2 certify engine oil, secondary choice to use JASOMa certify engine oil. Though ISW-40 is one of the engine oil which meet most of the environment temperature condition recommended by us, the engine oil viscosity also need be changed when the environment temperature condition change in you driving area changed. Please select according to right table.

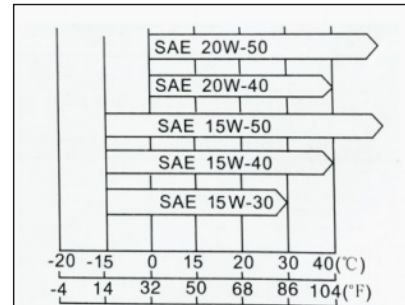

Replacing engine oil and filter

The replacement of the spark plug must follow the protocol from the chart.

Sparking plug model: CR6HSA

Sparking plug clearance **1**: 0.7mm~0.9mm

Tighten torque: 18N•m

Idling

The idle on this motorcycle has been adjusted by the factory before shipping. Riders cannot adjust the idle, otherwise, it will affect the whole set performance. You must calibrate the ECU again through failure diagnose instrument when needing to replace the components which affect idling.

 **Danger**

Failure to idle properly will result in damage

Idling: 1350r/min±150r/min

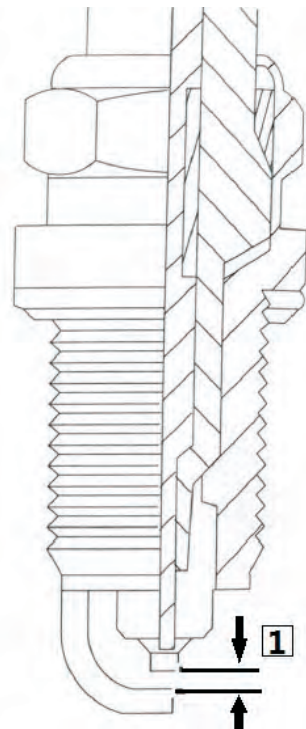

Air inlet/outlet system

Oil gas discharge monitor system

Typically found in a motorcycle's intake and exhaust system, an O₂, or oxygen, sensor is a data gathering component used on many fuel-injected motorcycles. An oxygen sensor sends measurements of the amount of oxygen flowing into the intake or exhaust system to the electronic control unit.

Intake valve

Essentially, valves act as the doors to the combustion chamber, allowing the fresh mix to flow in during the intake stroke, sealing the chamber during the compression and power strokes, and providing an exit for the spent gas during the exhaust stroke.

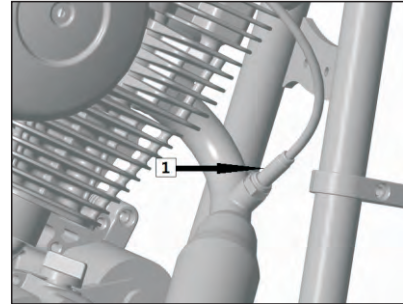

Air door clearance

The valve clearance generally points to the gap between the cam (or rocker) and the valve bucket. In order for you to do this successfully, you'll need some feeler gauges. Determine the clearance using trial and error by seeing which gauges can slip under the cam freely.

Warning

In a poorly adjusted valve, the reduced clearances causes the valve to spend less time seated. This will prohibit the exhaust valves from dissipating its heat. This excess heat will eventually become great enough to ignite the air-fuel mixture in the cylinder before the spark plug even fires. maintain chart.

Air filter

Air filter blockage will reduce the air inlet volume of engine, increase fuel consumption, reduce engine power and caused spark plug be foul. Air filter element should be cleaned according to maintenance chart. The air filter element must be maintained by your distributor and more frequently when driving in a dusty or damp environment.

Set the air filter oil discharge pipe **1** at back of engine, automatically discharge when air filter has residual oil or water.

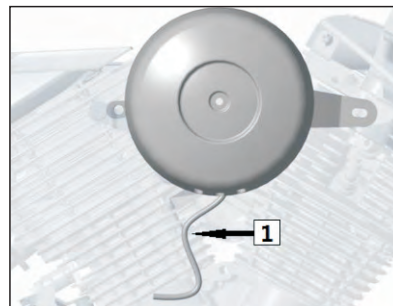

Warning

Running the engine without filtering the air can cause premature wear on internal parts. Never drive/ride motorcycle without air filter installed.

Air door clearance

Throttle valve spacing screw on throttle valve body has been pre-set, and can't be adjusted. Please consult you local dealer if idling is rough.

Tyre and chain

This motorcycle is equipped with tubed tires. Improper maintenance and installation or loss of air can cause serious injury.

Tyre specification

Tyre specification	Front wheel	4 x 17
	Rear wheel	4 x 17
Tyre air pressure	Front wheel	0.032psi
	Rear wheel	0.032psi
The min use depth of tire surface	Front wheel	0.8mm~1mm
	Rear wheel	0.8mm~1mm

Unsuitable tire air pressure or exceeding the load limit of tire may affect the operation and motorcycle performance and caused uncontrolled.

Use tire pressure gauge to check tire air pressure and adjust to manufacturers specifications. Low tire air pressure can cause abnormal wear and a possible blow out.

Correct tire air pressure will guarantee the best degree of comfort and longest working life of tire.

Attention

Check the tire air pressure when tire is cool.

Tire air pressure is affected by the change of stable environment and altitude height, and the tire air pressure must be checked and inspected when change of the ambient temperature and altitude height during your driving.

Most countries have their own stipulated min operating depth of tire surface, you must follow their requirements.

Check wheel balance when installing new wheel rim and tire.

Drive chain inspection

Inspection Before riding: the drive chain should be checked to make sure that it's adjusted and lubricated properly. The chain should be cleaned and re-lubricated when your ride is complete while the chain is still warm. This will allow the lubricant to penetrate the rollers and pins better.

Chain tension inspection

So what are the signs that tell you when you should service your chain? The first sign is mileage. The chain should be cleaned and then lubricated every 300 to 600 miles. Its important to regularly inspect your chain's tension and adjust it if needed. You'll have to consult your owners manual for the correct level of tension. Street bikes generally have 1.2-1.6 inches of slack while dirt bikes are in the 1.4-2.0 inch range. For more info on how to adjust your chain tension



Pay attention when spraying lubrication so that it does not end up on other parts that it could destroy.

Chain tension inspection

Shift in neutral;

Use side brace support the motorcycle;

Push the chain upward, confirming the degree of elasticity of chain;

Adjust to standard value if degree of elasticity of chain not in accordance.

Standard value: 30mm~40mm

Attention

The degree of wear of the chain is not always even. Rotate the rear wheel to different positions and repeatedly measure the degree of elasticity.

The degree of elasticity of drive chain adjustment

Loosen the rear wheel shaft nut **1**;

Left and right revolve to adjust the bolt **2** to adjust the degree of elasticity of chain;

Make sure left and right chain tension device **3** is same; the opposite position of marks and reference marks are same;

Make sure the tension device adjoin on the adjustment bolts;

Tightly twist the rear wheel shaft nut to recommend specifications.

25

Braking system

Several components of your braking system work together to help keep the driver safe. Therefore, keeping them well maintained will make the difference between encountering a huge accident or even a potential tragedy. Due to the importance of your braking system, it's a wise idea not to overlook its importance.

Front braking handle inspection

Front braking handle inspection

Use side brace support the motorcycle;

Lightly nip the brake handle to check the free stroke of brake handle;

Free stroke: 3mm~ 6mm

Check whether front brake handle has flaws and abnormal sounding, etc;

Replace any broken or worn parts.

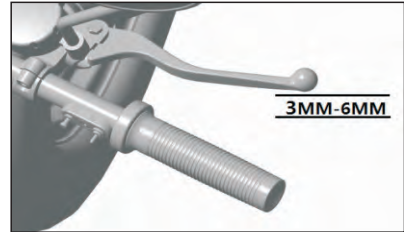

Back braking pedal bar inspection

Use side brace support the motorcycle;

Lightly shake the rear brake pedal bar to check the free stroke of rear brake pedal bar;

Free stroke: 10mm

Check whether rear brake handle has flaws and abnormal sounding, etc;

Replace any broken or worn parts.

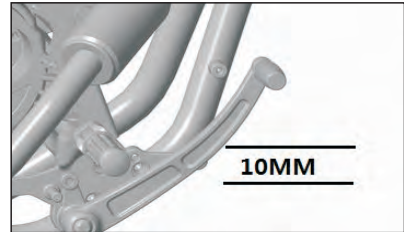

Warning

The Brake line may contain air or not enough brake liquid if feeling soft during operating brake handle and brake pedal. Do Not drive this motorcycle when the motorcycle has brake issues, contact your dealer to check the brakes immediately.

Brake oil level inspection (Please use DOT4 brake oil)

- (a) Full level, no need to add
- (b) Mid level, safe zone and will need brake fluid add
- (c) Low level, dangerous may cause spongy brakes or loss of braking power "Fill to level (a)"

Warning

Be sure to check the you brake system before and after every ride to ensure your safety and other motorist

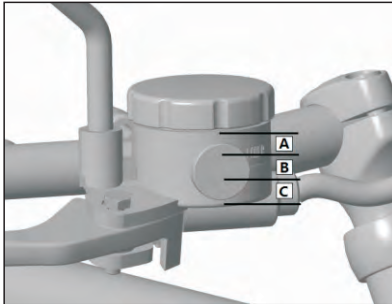

Front Reservoir

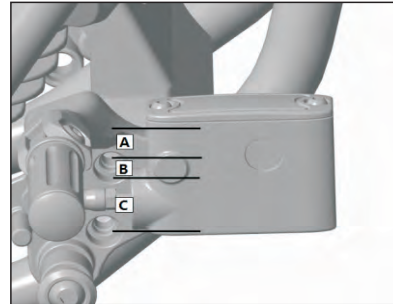

Rear Reservoir

Brake fluid

 **Warning**

The brake liquid can irritate your skin.

Make sure to place the brake liquid where children can't reach.

Don't let brake liquid touch skin, eyes or cloth, please wear protection clothing, wear eye protection glasses while working with.

Please see doctor immediately if swallowed.

Use a large quantity of fresh water flow to wash contacted skin, or eyes and see a doctor if it gets in your eyes.

Change clothes immediately if fluid gets on clothes.

 **Warning**

Change brake fluid as recommended in this book. Only use the DOT4 brake liquid which clearly marked on the oil cup. Mixed different brands brake liquid maybe caused brake system damaged.

Attention

Brake liquid descending will caused negative pressure in oil cup, this maybe caused oil cup hollow, need disassemble the oil cup cover and release pressure, reinstall oil cup pad and oil cup cover after adjusted the oil cup pad.

Front Reservoir

To remove move cap, turn counter clockwise, Fill to upper level to prevent brake failure.

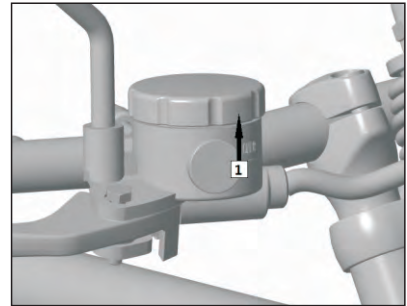

Rear Reservoir

To remove reservoir lid, remove the [2] Phillip screws. Fill to the upper lever. Be sure to fasten down the [2] phillip screws when done filling your reservoir to the upper lever.

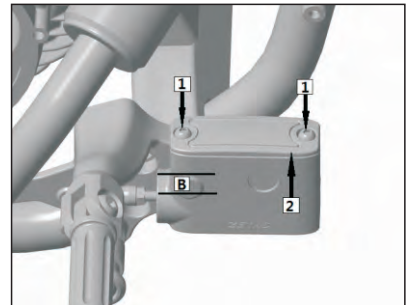

Brake tray inspection

Fix time check brake tray, check whether brake tray will damage, deformation, form flaws or wear, damaged brake tray can cause brakes to fail, worn brake tray will reduce braking distance, contact your dealer and replace with new brake tray immediately if find the brake tray damaged or over wear limit.

Test thickness of front and rear brake tray at multiply positions of brake tray.

Wear limit: 3mm

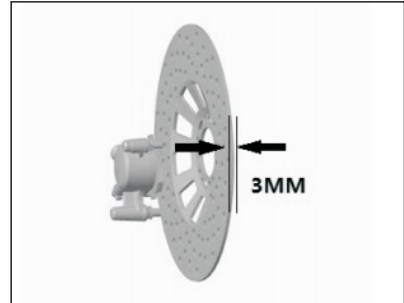

Brake Caliper inspection

Check brake caliper for abnormal wear before driving, check the min thickness of brake pads.

Check the min thickness of brake pad on all brake calipers.

The min thickness of pads: $\geq 1\text{mm}$ If thickness of brake pad is less than the min thickness of brake pads then contact the dealer to replace brake pads immediately, the brake pads must be replaced by the dealer.

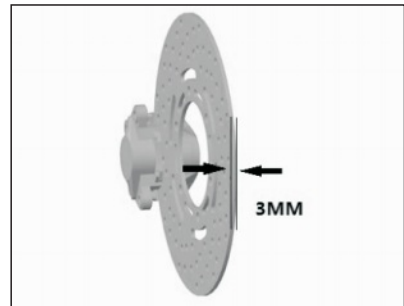

Spring front fork

Spring front fork inspection

Put pressure on the front forks with your weight to feel recoil.
If you do not an issue has occurred.

Back damper adjustment

Rear damper has been adjust at factory spec no other adjustments needed.

 **Danger**

Read the related instruction;
Don't throw it into fire, tapping or open.

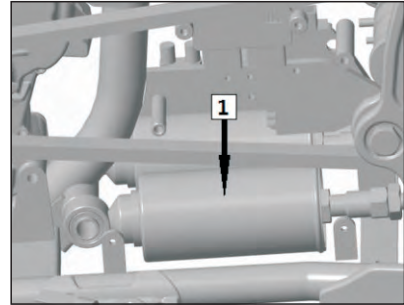

Electric and light signal

Battery

The battery installed in this motorcycle is a sealed type, so it is not necessary to check the battery electrolyte level or add distilled water.

Battery maintenance

It is the owner's responsibility to keep the battery fully charged. Failure to do so can lead to battery failure and leave you stranded. If you are riding your vehicle infrequently, inspect the battery voltage weekly using a voltmeter. If it drops below 12.6 volts, the battery should be charged using an appropriate charger (check with your local dealer). If you will not be using the motorcycle for longer than two weeks, the battery should be charged using an appropriate charger. Do not use an automotive-type quick charger that may overcharge the battery and damage it.

NOTE

Leaving the battery connected causes the electrical components (clock etc) to make the battery discharge, resulting the over discharge of the battery. In this case, the repair or replacement of the battery is not included in the warranty. If you do not drive for four weeks or more, disconnect the battery from the vehicle.

Light

Motorcycle headlight beam is adjustable. To do so, revolve light adjustment knob **1** to adjust the light.

Warning

Light adjustment must be in accordance with local laws, adjust the light with front and rear wheel on ground and driver sitting on the motorcycle.

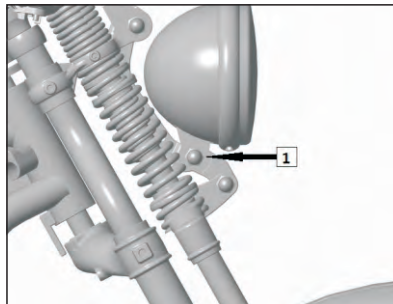

Headlight adjustment screws

Fuse

The fuse box is located behind **1** the guard plate. Remove the seat and middle connect plate of before guard plate then can see. Check whether electric system damage has occurred. If fuse is blown, then replace fuse with new.

Warning

Can't use any wire replace the corresponding fuse, use the same Ampere fuse to replace it. Marked the corresponding Ampere value on the fuse.

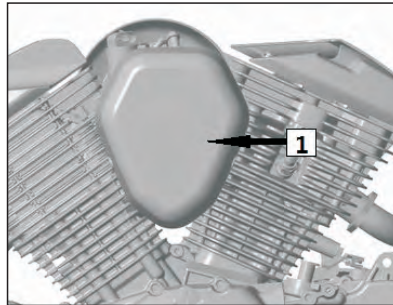

Catalyse device

The motorcycle catalyst serves an important function that has to do with environmental protection. It is responsible for making the gases leaving the engine of the vehicle less polluting and is a legal requirement for road going vehicles in most countries. This process of gas purification means there is a small loss of engine power.



Only use gasoline without lead, even though only contain few lead also will dirt the valuable metal if you catalyse device, make catalyse device invalid. Never add anti rust oil or engine oil in muffler, otherwise, it will make catalyse reaction invalid.

Fuel evaporation system

EVAP is an abbreviation which stands for Evaporative Emission Control System; yes, the name doesn't really match the abbreviation, but sometimes you have to go with things the way they are. Anyway, the main role of the EVAP system is to ensure zero fuel loss from the bikes through evaporation either from the fuel tanks or the fuel lines.

How to drive this vehicle



Danger

Riding is a very dangerous activity, so keep that in mind every time you ride and ride within your limits.

WARNING: Beginners should not underestimate the risks of riding! Always wear helmets, gloves, jackets and boots. You should practice on an empty parking lot before getting on public roads.

Start vehicle

First turn the key to ON position and you will see the dash lights up. Then find the neutral gear between the first and second gear. Pull the clutch in, use left foot to push the shift lever all the way down, then push it slightly up, and you should see the green “N” light up in the dash, which means the bike is now in neutral.



Warning

Do not press the starter button for too long, release it as soon as you hear the engine start.

Vehicle starting

Vehicle starting

Start the bike by switching the key to the “on” position and either pressing the ignition button or using the kickstart lever.

Shift, driving

Tightly hold the clutch handle and release throttle Shift to higher gears by pulling up on the gear shift with your foot. To shift down, push the gear shift down. Neutral is located halfway between 1st and 2nd gears.



Avoid suddenly changing load or applying strong brake operation, these operations may cause the motorcycle to become uncontrollable.

Adjust the motorcycle speed according to road status and around situation.

Please don't shift in low speed gear when at more higher engine speed, must release throttle first and reduce the engine speed.

All adjustment to motorcycle should be completed while motorcycle is parked.

Make sure the passengers sit on the passenger seat according to the requirements, feet place on the rear pedal, wear helmet and other safety protection. Hold on to driver.

Please follow the requirements relate to the lowest age of passengers in the locate country or regions.

Please follow the traffic rules, prevention and carefully drive, do best your to discriminate danger in advance.

Traction is reduced when the tires are low temperature, must be driving at middle speed carefully at the early few miles, until the tire achieves the running temperature.

Please don't exceed the allowed max total load, the total load include: preparation ready and fully fill fuel in motorcycle, driver, passenger and carried luggage.



Warning

Luggage and items sliding around will affect the driving performance. Check whether the luggage is firmly fixed on the motorcycle. Each side can't exceed beyond the motorcycle steering handle.

Thoroughly check your motorcycle before riding.

Incorrect shifting can cause damage to the gear shift box.

Pay attention to road condition. Wet or icy roads can cause sliding which could damage the motorcycle or injure the rider.

Braking

Use the front and rear brakes at the same tie.

Down shift into a lower speed as needed when braking.

Please utilize engine braking when going downhill to reduce force of the brake system and to avoid brakes overheating.



Warning

Moisture and dirt will affect braking system. If your brakes are damp, press the brakes several times. If the brakes are dusty, clean them.

IF the brakes or brake handles feel soft or loose, do not ride. Contact your dealer for a brake inspection.

Brake distances may be increased or decreased when carrying passengers or luggage. Adjust the brake time according to motorcycle load.

Parking

Use brakes to stop the motorcycle;

Shift in to neutral;

Turn off ignition;

Park the motorcycle on level ground;

Use kick stand to support the motorcycle;

Turn the handle bars to the left and use the key to lock the steering.

Remove key.



Warning

Operating or parking the vehicle near flammable materials can cause a fire, and can result in property damage or severe personal injury. Do not idle or park your vehicle in an area where tall or dry vegetation or other flammable materials could come into contact with the muffler or exhaust pipe.

The engine and exhaust system get extremely hot during normal operation and can cause serious burns. Never touch a hot engine, exhaust pipe, or muffler during the operation of after stopping the engine.

Do not park on a soft or steeply inclined surface, or the motorcycle may fall over.

Failure to perform these checks or to correct a problem before operation may result in serious damage or accident.

Safe Riding Techniques

Safety driving technique

The following are daily safe riding techniques. Please pay special attention to this section.

- Massimo strongly recommends both the operator and passenger wear a DOT-approved helmet even if it is not a legal requirement in your state. Make sure that your helmet fits correctly and is fastened.

- Always use eye protection. If your helmet does not have a visor installed, wear goggles.

- Wear gloves which have suitable protection for your hands, especially against abrasion.

- Wear protective clothing. Wear bright, highly visible clothing that allows freedom of movement to suit your riding style. Always wear a long sleeved jacket and long pants to protect against abrasion and keep you warm.

- Wear Protective boots that fit properly and do not interfere with gear shifting or braking.

- Keep hands on the handle bars, look over your shoulder and always accelerate and brake smoothly.

- When going up steep slopes, shift to a lower gear so there is power to spare rather than overloading the engine.

- When going down long slopes, help control vehicle speed by closing the throttle so that the engine can act as an auxiliary brake.

- Looseness in the steering can cause loss of control. Check to see that the handlebar turns freely but has no play.

- Examine tires in their overall condition, inflate them to proper pressure and check the wheel balance.

- Have sufficient fuel for the high fuel consumption during high speed operation.

- To avoid engine seizure and resulting loss of control, make sure that the oil level is at the upper level line.

- To avoid overheating, check that the coolant level is at the upper level line.

- Make sure that the headlight, tail/brake light, turn signals, horn, etc. all work properly.

- Make sure that nuts and bolts are tight and that all safety related parts are in good condition.

- Do not start moving or race the engine immediately after starting it, even if the engine is already warm. Run the engine at two or three minutes at idle speed to give the oil a chance to work up into all the engine parts.

Your Massimo motorcycle has been designed and manufactured to provide you optimum safety and convenience. However, in order to fully benefit from Massimo's safety engineering and craftsmanship, it is essential that you, the owner and operator, properly maintain your motorcycle and become thoroughly familiar with its operation. Improper maintenance can create a dangerous situation know at throttle failure.

Daily safety inspection

Check the below items before daily driving, develop this habit will guarantee the safety of drive this motorcycle and reliability of motorcycle. Please check the adjustment chapter or contact your distributor to maintain if find any abnormal sounds.



Danger

Continue drive if find abnormal, this maybe caused that seriously damage motorcycle or happen unexpected accidents.

Fuel	Do not overfill
Engine oil	Keep engine oil level at middle of the up limit mark line and down limit mark line of engine oil observe window.
Tire	Tire air pressure (cooling status)

Install air door nozzle cover

Drive chain	30mm~40mm, use lubricant when dry.
Nuts, bolts and fasteners	check the torque and the degree of fasten of operating and suspending components, shafts and all control components.
Operating	The actions should be flexible and smooth, but locked parts can't loosen.and not wrapped around the cable.
Brake	Brake pads wear over time. The min valid thickness should be larger than 1mm.
Throttle	Clearance: 2mm~3mm
Electrical	Alllights (front headlight, tail lamp/brake lamp, turn lamp, warning/signal indicate lamp) should be fully functional
Engine misfire switch	Normal function.
Kick Stand	Reset spring isn't loose, worn, or damaged.

Read all warning contents on motorcycle.

Pay attention while driving at high speeds

Brake: When driving at a high speed, it is important not to brake too hard.

Operating: Loose parts may cause the motorcycle to become uncontrolled.

Tire: the tire should be firm and properly inflated when driving at high speeds. Check air pressure and for stable turning.

Fuel: Keep enough fuel in the tank to smoothly supply oil through the motorcycle.

Engine oil: Keep engine oil level between the limit UP line and limit DOWN line to avoid engine occur failure.

Electric devices: Check to make sure all front headlights, tail lamps/brake lamps, turn lamps, warning/signals indicate lamp and horn are working properly.

Fasteners: make ensure all nuts and bolts are firm, and that all components which relate to safety are in good operating shape.



Danger

Do not speed and follow the all local laws and regulations.

Break-in period

- For the first 500 to 1,000 miles, avoid using more than $\frac{3}{4}$ throttle.
- Always avert high engine speeds.
- Do not make hard stops, aggressive starts, or rapid acceleration unless there is an emergency.
- While breaking in your motorcycle, increase your bike's engine speed to the rev

Total mileage of motorcycle driving	The highest engine speed
0km~500km	4000r/min
500km~1000km	6000r/min



Do not speed and, follow the related laws and regulations, except that obtained permission of the traffic control department, and have the related skills and protection conditions.

Periodic Maintenance

*A: Service at number of years shown or indicated odometer reading intervals, whichever comes first.

*B: For higher odometer readings, repeat at the frequency interval established here.

*C: Service more frequently when operating in severe conditions: dusty, wet, muddy, high speed, or frequent starting / stopping.

*D: California Model only

O: Emission Related Item

 :Inspection

 Dealer Inspection

 :Change or Replace

 Dealer Change or Replace























 :Lubrication

 Dealer Lubrication

MAINTENANCE AND ADJUSTMENT

Items		Year (*A)	Odometer Reading(*B) × 1000Km(× 1000mile)				
			1 (0.6)	6 (3.8)	12 (7.6)	18 (11.4)	24 (15.2)
<input type="radio"/>	Air cleaner element(*C)	↻:2			Q		Q
<input type="radio"/>	Idle speed		Q		Q		Q
<input type="radio"/>	Throttle control system(play,smooth return, no drag)	Q:1	Q		Q		Q
<input type="radio"/>	Engine vacuum synchronization				Q		Q
	Fuel system	Q:1	Q		Q		Q
	Fuel hose	↻:5					
<input type="radio"/>	Evaporative emission control system(*D)			Q	Q	Q	Q
	Coolant level		Q		Q		Q
	Cooling system	Q:1	Q		Q		Q









MAINTENANCE AND ADJUSTMENT

Items		Year (*A)	Odometer Reading(*B) × 1000Km(× 1000mile)				
			1 (0.6)	6 (3.8)	12 (7.6)	18 (11.4)	24 (15.2)
	Coolant, water hoses and O-rings	 :3	 :every 36,000 Km(22,500 mile)				
○	Valve clearance						
○	Air suction system						
	Clutch operation(play, engagement, disengagement)						
	Engine oil and Oil filter(*C)	 :1					
	Tire air pressure	 :1					
	Wheels and tires	 :1					
	Wheels bearing damage	 :1					
	Drive chain lubrication condition(*C)		 :every 600 Km(400 mile)				

MAINTENANCE AND ADJUSTMENT

Items		Year (*A)	Odometer Reading(*B) × 1000Km(× 1000mile)				
			1 (0.6)	6 (3.8)	12 (7.6)	18 (11.4)	24 (15.2)
	Drive chain slack(*C)		Q :every 1,000 Km(600 mile)				
	Drive chain wear(*C)				Q		Q
	Drive chain guide wear				Q		Q
	Brake system	Q:1	Q	Q	Q	Q	Q
	Brake fluid level	Q:0.5	Q	Q	Q	Q	Q
	Brake fluid (front and rear)	↻:2					↻
	Brake hose/rubber parts of brakemaster cylinder and caliper	↻:4	↻ :every 48,000 Km(30,000 mile)				
	Brake pad wear(*C)			Q	Q	Q	Q
	Brake light switch operation		Q	Q	Q	Q	Q

MAINTENANCE AND ADJUSTMENT

Items		Year (*A)	Odometer Reading(*B) × 1000Km(× 1000mile)				
			1 (0.6)	6 (3.8)	12 (7.6)	18 (11.4)	24 (15.2)
	Suspension System	Q:1			Q		Q
	Lubrication of rear suspension						
	Steering play	Q:1	Q		Q		Q
	Steering stem bearings	 :2					
	Electrical system	Q:1			Q		Q
○	Spark plugs						
	Chassis parts	 :2					
	Condition of bolts, nuts and fasteners		Q		Q		Q

Tampering With Noise Control System Prohibited

Federal law prohibits the following acts or the causing thereof:

- (1) the removal or rendering inoperative by any person other than for purposes of maintenance, repair, or replacement, of any device or element of design incorporated into any new vehicle for the purpose of noise control prior to its sale or delivery to the ultimate purchaser or while it is in use, or
- (2) the use of the vehicle after such device or element of design has been removed or rendered inoperative by any person.

Among those acts presumed to constitute tampering are the acts listed below:

- * Replacement of the original exhaust system or muffler with a component not in compliance with federal regulations.
- * Removal of the muffler(s) or any internal portion of the muffler(s).
- * Removal of the air box or air box cover.
- * Modifications to the muffler(s) or air intake system by cutting, drilling, or other means if such modifications result in increased noise levels.

MAINTENANCE RECORD

Owner Name
Address
Phone Number
Engine Number
Vehicle Number
Key code.....
Selling Deater Name
Phone Number
Warranty Start Date

Note: Keep this information and a spare key in a secure location.

Date	Odomter Reading	Maintenance Performed	Dealer Name	Dealer Address

MAINTENANCE RECORD

Date	Odomter Reading	Maintenance Performed	Dealer Name	Dealer Address

Common failure and trouble shoot

Failures	Systems	Reason	Solution
No start	Fuel system	No fuel in fuel tank	Fill fuel
		Fuel pump blocked or damaged: bad fuel quality	Check or replace
	Ignite system	Sparking pug failure: accumulated carbon	Check or replace
		Sparking plug cap failure: bad contact or burned out	Check or replace
		Ignite coil failure: bad contact or burned out	Check or replace
		ECU failure: bad contact or burned out	Check or replace
		Trigger coil failure: improper gap or bumed out	Check or replace
		Stator failure: ground winding or burned out	Check or replace
		Wire connector / plug failure	Check or replace
	Compression	Worn decompression release	Check or replace
		Loose valves	Check or replace
		Worn piston rings and cylinder	Check or replace
		Blown head gasket	Check or replace
Timing		Check or replace	
Loss of Power	Throttle body	Stuck butterfly valve, stuck idle air control valve	Check or replace
	Clutch	Clutch slipping	Adjust or renewal
	Cylinder body, ring	Cylinder body, piston ring wear	Check or replace
	Brakes	Brakes dragging	Adjust or replace
	Drive chain	Drive chain too tight	Adjust or replace
	Engine	Lean or rich mixtures of fuel or low level of oil my cause engine failure	Repair or replace

Loss of power	Sparking plug	Unsuitable sparking plug clearance: normal: 0.8mm-0.9mm	Adjust or replace
	Air inlet pipe	Air inlet pipe air leak	Adjust or repair
	Valves	Loose valves	Check or Adjust
	Electric system	Electrical system has failure	Check or repair
	Air filter	Check cleanliness	Clean or replace
Bad front headlight, tail lamp	Wiring	Bad circuit connection	Adjust
	Left/right switch	Bad switch contact or damaged	Adjust or replace
	Headlight	Lamp bulb, lamp base failure or damaged	Adjust or replace
	Voltage regulator	Inspect Voltage regulator	Check or replace
	Stator	Bad contact or burned out	Change or replace
No sound from horn	Battery	Low battery voltage	Charge or replace
	Left switch	Horn switch failure or damaged	Change or replace
	Wiring	Check connection / connectors	Adjust or repair
	Horn	Horn damaged	Change or replace

You are responsible for maintaining you vehide according to the maintenance schedule shown in this owner's manual



ZETHS VEHICLE TECHNOLOGY CO.,LTD

Made in China